

DIMENSIONS

MILLIMETERS(INCHES)

MPW - 01

Pilot Operated Check Valves(Modular Type)

MOUNTING SURFACE:MP*-01-CETOP3
ISO 03-NFPAD03

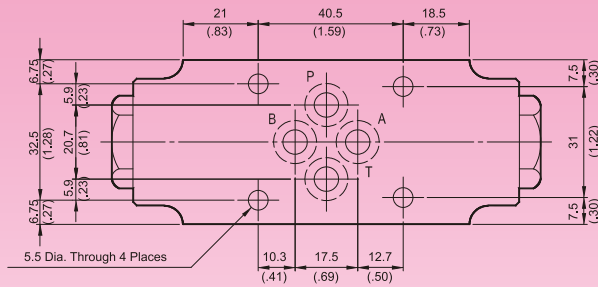

Valve Specifications & Attachment

Flow Rating	50 lpm (13.2 gpm)
Max. Pressure	250 bar (3600 psi)
Weight kg.(lbs.)	1.2 (2.6)
CODE:20	M5 X85LgX4pcs
CODE:2090	10-24UNCX3-1/4"LgX4pcs
Mounting Surface O-Ring P9 x 4 pc	



SYMBOL



D

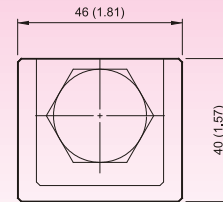
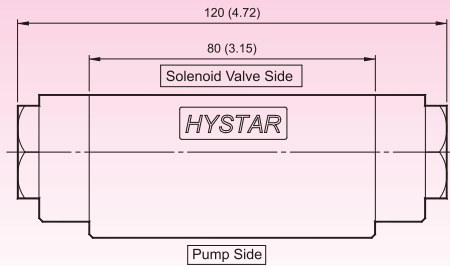

MPW - 03

Pilot Operated Check Valves(Modular Type)

MOUNTING SURFACE:MP*-03-CETOP5
ISO 05-NFPAD05

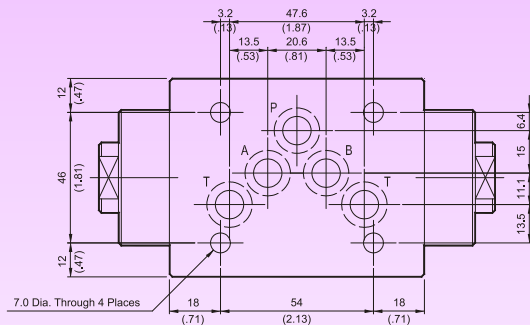

Valve Specifications & Attachment

Flow Rating	100 lpm (26.5 gpm)
Max. Pressure	250 bar (3600 psi)
Weight kg.(lbs.)	3.5 (7.7)
CODE:20	M6 X90LgX4pcs
CODE:2090	1/4-20UNCX3-1/2LgX4pcs
Mounting Surface O-Ring P12 x 5 pc	



SYMBOL



MPW-03-30

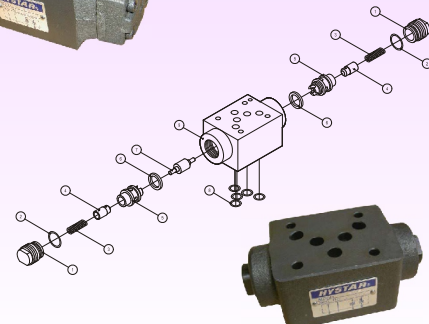
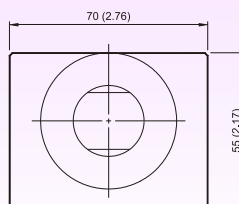
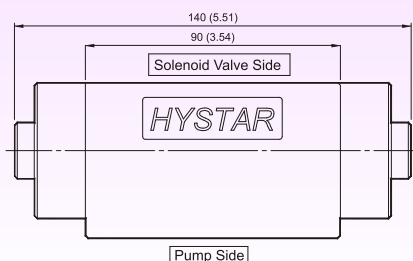



DIMENSIONS

MILLIMETERS(INCHES)

MPW - 04 Pilot Operated Check Valves(Modular Type)

MOUNTING SURFACE:MP*-04-CETOP7
ISO 07-NFPAD07

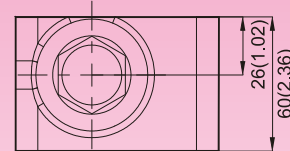
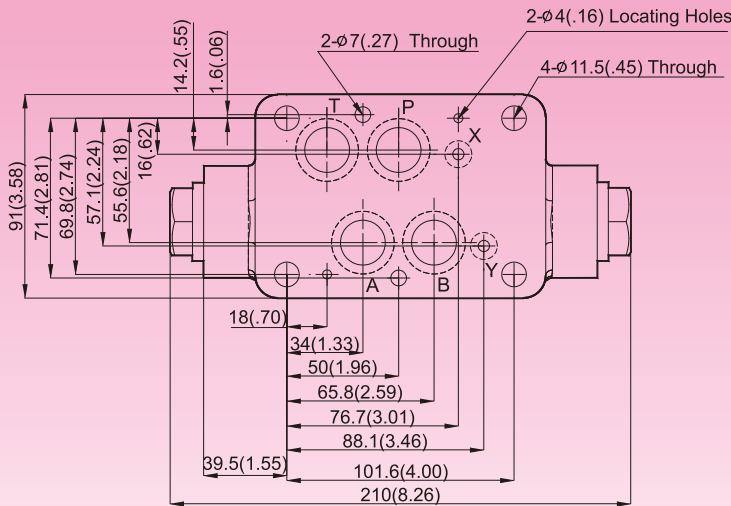

MPA-04
MPB-04
MPW-04

Valve Specifications & Attachment

Flow Rating	190 lpm (50.2 gpm)
Max. Pressure	250 bar (3600 psi)
Weight kg.(lbs.)	7.0 (15.4)
CODE:20	M6X125LgX2pcs M10X120LgX4pcs
CODE:2090	1/4-20UNCX4-7/8"LgX2pcs 3/8-16UNCX4-5/8"Lg X4pcs
Mounting Surface O-Ring P9 x 2 pc & P22A x 4 pcs	

MPW - 06 Pilot Operated Check Valves(Modular Type)

MOUNTING SURFACE:MP*-06-CETOP8
ISO 08-NFPAD08

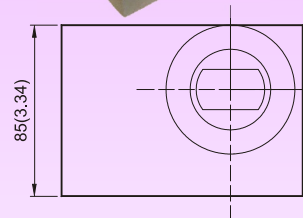
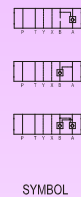
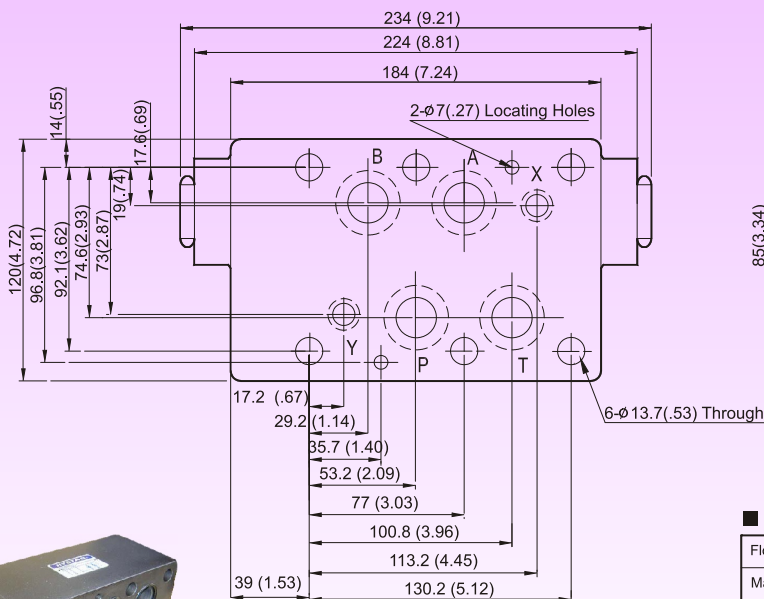

MPA-06
MPB-06
MPW-06

Valve Specifications & Attachment

Flow Rating	300 lpm (79.3 gpm)
Max. Pressure	250 bar (3600 psi)
Weight kg.(lbs.)	11.2 (24.6)
CODE:20	M12X140LgX6pcs
CODE:2090	1/2-13UNCX4-5/8"Lg X6pcs
Mounting Surface O-Ring P12 x 2 pc, P28 x 4 pcs	

SEQUENCE VALVES & COUNTER BALANCE MODULAR VALVES

- Sequence Valves (Modular Type) - MHP-0*-*
- Counter-balance Valves (Modular Type) - MHA(B)-0*-*

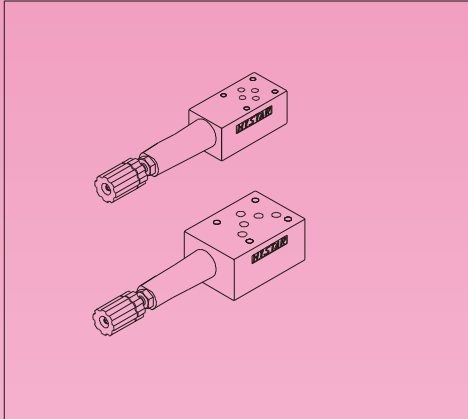

Model & Symbol	Model & Symbol
MHP-01 (03)	MHP-04 (06)
MHA-01 (03)	MHA-04 (06)
MHB-01 (03)	MHB-04 (06)



■ Ratings

Model	Max Operating Pres bar (PSI)	Max Flow lpm (USgpm)	Valve Size	Weight kg (lb)
MH*-01-*	250 (3600)	50 (13.2)	1/8"	1.1 (2.4)
MH*-03-*	250 (3600)	100 (26.5)	3/8"	3.8 (8.3)
MH*-04-*	250 (3600)	190 (50.2)	1/2"	7.0 (15.4)
MH*-06-*	250 (3600)	300 (79.3)	3/4"	11.2 (24.6)

* This sequence modular valves (MHP-0*-*) is used for actuator sequential operation, as well as for circuit pressure holding. With wide adjustment range 6 ~ 250 bar. hydraulic circuit and also serves as a safety valve.

* MHA(B)-0*-* counter-balance modular valves is used for actuator back pressure control.



■ Ordering Code

MH - P - 01 - C - 20 - S

Series No	Control Line	Valve Size	Pressure Adj. Range	Design No	Special Kits
MHP Sequence Modular Valves	P : P Port 	(DSG-) 01 (NFPA-D03) 	N: 6~ 18 bar 	20 DIN 912 bolts 	None: With Knob
MHA(B) Counterbalance Modular Valves	A : A Port 	(DSG-) 03 (NFPA-D05) 	A: 18~ 35 bar 	2090 UNC bolts (North America) 	S: Soc. Hd. Cap Screw
	B : B Port 	(DSHG-) 04 (NFPA-D07) 	B: 35~ 70 bar 		
		(DSHG-) 06 (NFPA-D08) 	C: 70~ 250 bar 		

