



ROLLER CHAIN

Mechanical
Electrical

Table des matières / *Index*

Sélection

- p.3 - Chaînes à rouleaux ANSI standard
- p.6 - Chaînes à rouleaux à pas double—Type A
- P.7 - Chaînes à rouleaux à pas double - Type C
- p.9 - Chaînes à rouleaux de type O-ring
- p.10 - Chaînes à rouleaux de type HD

Entretien

- p.12 - Vérification de la chaîne à rouleaux

Selection

- *p.3 - Single pitch roller chain*
- *p.6 - Type A - Double pitch roller chain*
- *p.7 - Type C - Double pitch roller chain*
- *p.9 - O-ring type roller chain*
- *p.10 - HD type roller chain*

Maintenance

- *p.12 - Verification of the roller chain*

SELECTION

Chaînes à rouleaux ANSI Standard / Roller Chains ANSI Standard

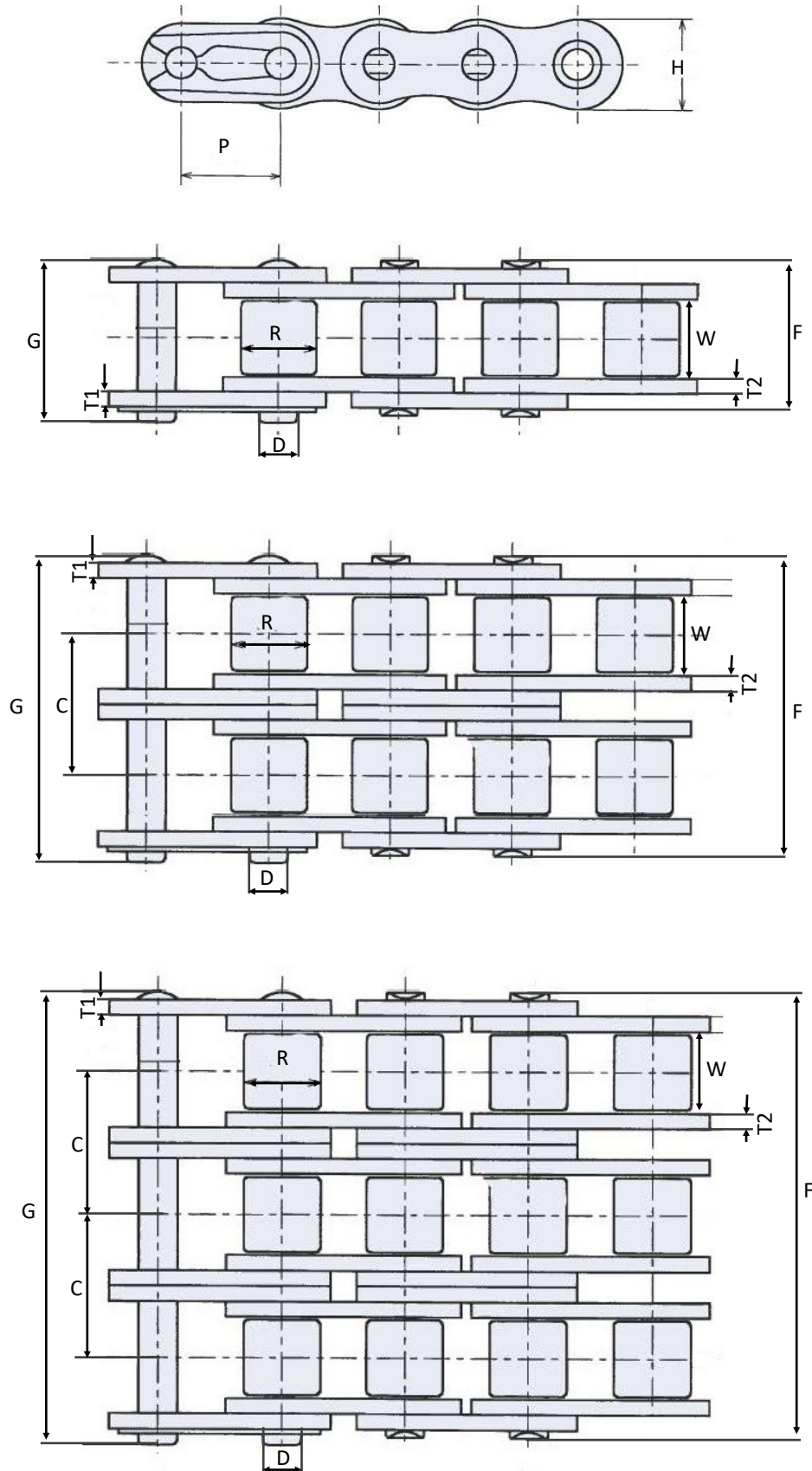

Les valeurs des dimensions se trouvent à la page suivante.

The value for the dimensions will be found on the following page.

SELECTION

Chaînes à rouleaux ANSI Standard / Roller Chains ANSI Standard

# Chaîne Chain number	Pas Pitch		Largeur chaîne (min) Chain width	Largeur rouleau (max) Roller Width	Plaque Plate			Goupille Pin			Pas apparent Transverse Pitch	Force de traction minimum ultime Ultimate minimum tensile Strength kN / (lbs)	Poids approximatif Approximative Weight kg/m / (lb/ft)	Charge de service Working Load kgs (lbs)
	P po/in	P mm			W mm (po/in)	R mm (po/in)	H mm (po/in)	T1 mm (po/in)	T2 mm (po/in)	D mm (po/in)				
25-1	1/4	6.35	2.99 (0.118)	2.99 (0.118)	5.99 (0.236)	20.32 (0.80)	20.32 (0.80)	2.00 (0.079)	8.99 (0.354)	10.99 (0.433)	—	3.50 (795)	0.14 (0.094)	63.6 (140)
25-2*	1/4	6.35	2.99 (0.118)	2.99 (0.118)	5.99 (0.236)	20.32 (0.80)	20.32 (0.80)	2.00 (0.079)	14.98 (0.59)	16.00 (0.63)	5.99 (0.236)	7.00 (1591)	0.26 (0.1747)	108.94 (240)
25-3*	1/4	6.35	2.99 (0.118)	2.99 (0.118)	5.99 (0.236)	20.32 (0.80)	20.32 (0.80)	2.00 (0.079)	21.00 (0.827)	21.00 (0.827)	5.99 (0.236)	10.5 (2386)	0.40 (0.2687)	142.26 (320)
35-1	3/8	9.52	3.98 (0.157)	5.00 (0.197)	8.99 (0.354)	0.99 (0.039)	0.99 (0.039)	2.99 (0.118)	13.00 (0.512)	13.97 (0.55)	—	7.90 (1795)	0.33 (0.2217)	217.88 (480)
35-2*	3/8	9.52	3.98 (0.157)	5.00 (0.197)	8.99 (0.354)	0.99 (0.039)	0.99 (0.039)	2.99 (0.118)	23.01 (0.906)	24.00 (0.945)	10.00 (0.394)	15.80 (3591)	0.69 (0.4636)	367.68 (810)
35-3*	3/8	9.52	3.99 (0.1574)	5.00 (0.197)	8.99 (0.354)	0.99 (0.039)	0.99 (0.039)	2.99 (0.118)	32.00 (1.26)	32.99 (1.299)	10.00 (0.394)	23.7 (5386)	1.05 (0.7056)	544.71 (1200)
41*	1/2	12.7	5.99 (0.236)	7.01 (0.276)	8.99 (0.354)	0.99 (0.039)	0.99 (0.039)	2.99 (0.118)	13.97 (0.55)	14.98 (0.59)	—	6.67 (1516)	0.41 (0.2755)	226.97 (500)
40-1	1/2	12.7	7.00 (0.2756)	7.01 (0.276)	11.98 (0.472)	9.98 (0.393)	9.98 (0.393)	2.99 (0.118)	17.01 (0.67)	18.00 (0.709)	—	14.10 (3205)	0.63 (0.4233)	367.68 (810)
40-2*	1/2	12.7	7.00 (0.2756)	7.01 (0.276)	11.98 (0.472)	9.98 (0.393)	9.98 (0.393)	2.99 (0.118)	30.98 (1.22)	34.03 (1.34)	13.97 (0.55)	28.20 (6409)	1.19 (0.7996)	624.88 (1370)
40-3*	1/2	12.7	7.00 (0.2756)	7.01 (0.276)	11.98 (0.472)	9.98 (0.393)	9.98 (0.393)	2.99 (0.118)	44.95 (1.77)	45.99 (1.811)	13.97 (0.55)	42.3 (9614)	1.77 (1.1893)	919.2 (2025)
50-1	5/8	15.87	8.99 (0.354)	9.99 (0.3937)	15.01 (0.591)	1.99 (0.0787)	1.99 (0.0787)	5.00 (0.197)	21.00 (0.827)	21.99 (0.866)	—	22.20 (5045)	1.01 (0.6789)	635.49 (1400)
50-2*	5/8	15.87	8.99 (0.354)	9.99 (0.3937)	15.01 (0.591)	1.99 (0.0787)	1.99 (0.0787)	5.00 (0.197)	38.98 (1.535)	42.01 (1.654)	18.00 (0.709)	44.40 (10091)	2.04 (1.3708)	1080.34 (2380)
50-3*	5/8	15.87	8.99 (0.354)	9.99 (0.3937)	15.01 (0.591)	1.99 (0.0787)	1.99 (0.0787)	5.00 (0.197)	56.99 (2.244)	61.97 (2.44)	18.00 (0.709)	66.73 (14982)	3.05 (2.0495)	1588.73 (3500)
60-1	3/4	19.05	11.99 (0.4724)	10.99 (0.433)	18.00 (0.709)	1.99 (0.0787)	1.99 (0.0787)	5.00 (0.197)	26.00 (1.024)	27.00 (1.063)	—	31.80 (7227)	1.44 (0.9676)	885.15 (1950)
60-2*	3/4	19.05	11.99 (0.4724)	10.99 (0.433)	18.00 (0.709)	1.99 (0.0787)	1.99 (0.0787)	5.00 (0.197)	49.02 (1.93)	51.05 (2.01)	21.99 (0.866)	63.60 (14455)	3.03 (2.0360)	1504.76 (3315)
60-3*	3/4	19.05	11.99 (0.4724)	10.99 (0.433)	18.00 (0.709)	1.99 (0.0787)	1.99 (0.0787)	5.00 (0.197)	70.99 (2.795)	72.89 (2.87)	21.99 (0.866)	95.4 (21682)	4.50 (3.023)	2212.88 (4875)

*: Ce type de chaîne est disponible sur demande seulement // This type of chain is available on demand only

SELECTION

Chaînes à rouleaux ANSI Standard / Roller Chains ANSI Standard

# Chaîne Chain number	Pas Pitch		Largeur chaîne (min) Chain width	Largeur rouleau (max) Roller Width	Plaque Plate			Goupille Pin			Pas apparent Transverse Pitch	Force de traction minimum ultime Ultimate minimum tensile Strength kN / (lbs)	Poids approximatif Approximative Weight kg/m / (lb/ft)	Charge de service Working Load kgs / (lbs)			
	P	P			W	R	H	T1	T2	D					F	G	C
	po/in	mm			mm (po/in)	mm (po/in)	mm (po/in)	mm (po/in)	mm (po/in)	mm (po/in)					mm (po/in)	mm (po/in)	mm (po/in)
80-1	1	25.40	15.75 (0.62)	15.88 (0.62)	24.13 (0.949)	3.25 (0.12)	3.25 (0.12)	7.94 (0.312)	33.5 (1.318)	35.0 (1.37)	—	56.70 (12886)	2.40 (1.6127)	1496.85 (3300)			
80-2*	1	25.40	15.75 (0.62)	15.88 (0.62)	24.13 (0.949)	3.25 (0.12)	3.25 (0.12)	7.94 (0.312)	62.7 (2.46)	64.3 (2.53)	29.29 (1.15)	113.40 (25772)	5.26 (3.5345)	2544.65 (5610)			
80-3*	1	25.40	15.75 (0.62)	15.88 (0.62)	24.10 (0.948)	3.25 (0.12)	3.25 (0.12)	7.92 (0.311)	91.7 (3.61)	93.6 (3.68)	29.29 (1.15)	170.1 (38659)	7.80 (5.2413)	3742.13 (8250)			
100-1	1-1/4	31.75	18.90 (0.74)	19.05 (0.74)	30.17 (1.187)	4.0 (0.15)	4.0 (0.15)	9.54 (0.375)	41.1 (1.61)	44.70 (1.75)	—	88.50 (20114)	3.74 (2.5131)	2295.17 (5060)			
100-2*	1-1/4	31.75	18.90 (0.74)	19.05 (0.74)	30.17 (1.187)	4.0 (0.15)	4.0 (0.15)	9.54 (0.375)	77.0 (3.03)	80.5 (3.16)	35.76 (1.40)	177.00 (40227)	7.51 (5.0464)	3900.89 (8600)			
100-3*	1-1/4	31.75	18.90 (0.74)	19.05 (0.74)	30.10 (1.185)	4.0 (0.15)	4.0 (0.15)	9.53 (0.375)	112.2 (4.41)	116.3 (4.57)	35.76 (1.40)	265.5 (60341)	11.20 (7.5260)	5737.94 (12650)			
120-1	1-1/2	38.10	25.22 (0.99)	22.23 (0.87)	36.20 (1.42)	4.80 (0.18)	4.80 (0.18)	11.11 (0.437)	50.8 (1.99)	54.30 (2.13)	—	127.00 (28864)	6.18 (4.1527)	3084.42 (6800)			
120-2*	1-1/2	38.10	25.22 (0.99)	22.23 (0.87)	36.20 (1.42)	4.80 (0.18)	4.80 (0.18)	11.11 (0.437)	96.3 (3.79)	99.7 (3.92)	45.44 (1.78)	254.00 (57727)	12.25 (8.2316)	5243.52 (11560)			
120-3*	1-1/2	38.10	25.22 (0.99)	22.23 (0.87)	36.10 (1.42)	4.80 (0.18)	4.80 (0.18)	11.10 (0.437)	141.4 (5.56)	145.2 (5.71)	45.44 (1.78)	381.0 (86591)	18.30 (12.2970)	7711.07 (17000)			
140-1	1-3/4	44.45	25.22 (0.99)	25.40 (0.99)	42.23 (1.66)	5.60 (0.22)	5.60 (0.22)	12.71 (0.50)	54.9 (2.16)	59.0 (2.32)	—	172.40 (39182)	7.49 (5.0330)	4082.33 (9000)			
140-2*	1-3/4	44.45	25.22 (0.99)	25.40 (0.99)	42.23 (1.66)	5.60 (0.22)	5.60 (0.22)	12.71 (0.50)	103.6 (4.07)	110.9 (4.36)	48.87 (1.92)	344.80 (78364)	14.83 (9.9652)	6939.96 (15300)			
140-3*	1-3/4	44.45	25.22 (0.99)	25.40 (0.99)	41.00 (1.61)	5.60 (0.22)	5.60 (0.22)	12.70 (0.49)	152.2 (5.99)	156.8 (6.17)	48.87 (1.92)	517.2 (117545)	22.20 (14.9177)	10205.83 (22500)			
160-1	2	50.80	31.55 (1.24)	28.58 (1.125)	48.26 (1.89)	6.40 (0.25)	6.40 (0.25)	14.29 (0.56)	65.5 (2.57)	69.60 (2.74)	—	226.80 (51545)	10.10 (6.7868)	5397.74 (11900)			
160-2*	2	50.80	31.55 (1.24)	28.58 (1.125)	48.26 (1.89)	6.40 (0.25)	6.40 (0.25)	14.29 (0.56)	124.2 (4.88)	128.1 (5.04)	58.55 (2.30)	453.60 (103091)	20.04 (13.4662)	9176.17 (20230)			
160-3*	2	50.80	31.55 (1.24)	28.58 (1.125)	48.00 (1.88)	6.40 (0.25)	6.40 (0.25)	14.29 (0.56)	181.8 (7.15)	186.6 (7.34)	58.55 (2.30)	680.41 (154636)	30.20 (20.2934)	13494.37 (29750)			

*: Ce type de chaîne est disponible sur demande seulement // This type of chain is available on demand only

SELECTION

Chaînes à rouleaux de type A – Double pas ANSI standard Type A Roller Chain - Double Pitch ANSI standard

# Chaîne Chain number	Pas Pitch		Largeur chaîne (min) Chain width	Largeur rouleau (max) Roller Width	Plaque Plate			Goupille Pin			Pas apparent Transverse Pitch	Force de traction minimum ultime Ultimate minimum tensile Strength kN / (lbs)	Poids approximatif Approximate Weight kg/m / (lb/ft)	Charge de service Working Load kgs (lbs)
	P po/in	P mm			H mm (po/in)	T1 mm (po/in)	T2 mm (po/in)	D mm (po/in)	F mm (po/in)	G mm (po/in)				
	W mm (po/in)	R mm (po/in)	Hauteur max Max Height	Épaisseur 1 Thickness 1	Épaisseur 2 Thickness 2	Diamètre max Max Diameter	Longueur max Max Length							
A2040*	1"	25.40	7.85 (0.30)	7.95 (0.31)	12.07 (0.47)	1.5 (0.05)	1.5 (0.05)	3.98 (0.15)	17.8 (0.67)	18.8 (0.74)	—	14.1 (3172)	0.42 (0.282)	269.88 (595)
A2050*	1-1/4"	31.75	9.40 (0.37)	10.16 (0.39)	15.09 (0.59)	2 (0.07)	2 (0.07)	5.09 (0.20)	21.8 (0.85)	22.6 (0.88)	—	22.2 (4994)	0.73 (0.491)	439.98 (970)
A2060*	1-1/2"	38.10	12.57 (0.49)	11.91 (0.46)	18.10 (0.71)	2.42 (0.09)	2.42 (0.09)	5.96 (0.23)	26.9 (1.05)	27.7 (1.09)	—	31.8 (7154)	1.02 (0.685)	997.90 (2200)
A2080*	2"	50.80	15.75 (0.62)	15.88 (0.62)	24.13 (0.94)	3.25 (0.12)	3.25 (0.12)	7.94 (0.31)	33.5 (1.31)	35.0 (1.37)	—	56.7 (12755)	1.70 (1.142)	N/A
A2080H**	2"	50.80	15.75 (0.62)	15.88 (0.62)	24.13 (0.94)	4.0 (0.15)	4.0 (0.15)	7.92 (0.31)	36.2 (1.42)	39.4 (1.55)	—	59.7 (13430)	2.17 (1.458)	1088.62 (2400)
A2100**	2-1/2"	63.50	18.90 (0.74)	19.05 (0.74)	30.17 (1.187)	4.0 (0.15)	4.0 (0.15)	9.54 (0.37)	41.1 (1.61)	44.7 (1.75)	—	88.5 (19909)	2.55 (1.714)	1741.79 (3840)
A2120**	3"	76.20	25.22 (0.99)	22.23 (0.87)	36.20 (1.42)	4.80 (0.18)	4.80 (0.18)	11.11 (0.43)	50.8 (1.99)	54.3 (2.13)	—	127.0 (28570)	4.06 (2.728)	2440.32 (5380)

*: Ce type de chaîne est disponible sur demande seulement // This type of chain is available on demand only

** : À développer avec le fournisseur // To develop with the supplier

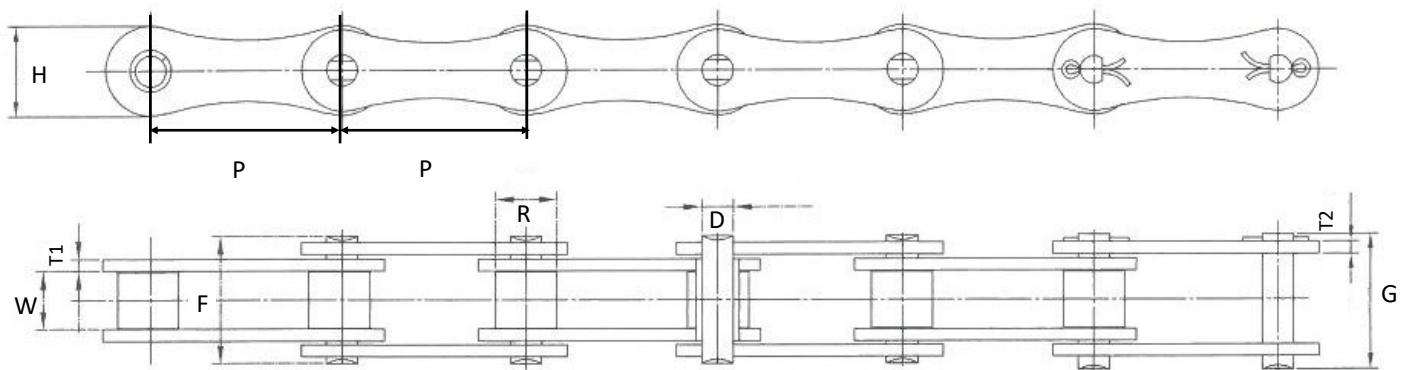

SELECTION

Chaînes à rouleaux de type C – Double pas ANSI standard et type H Type C Roller Chain - Double Pitch ANSI standard and H type

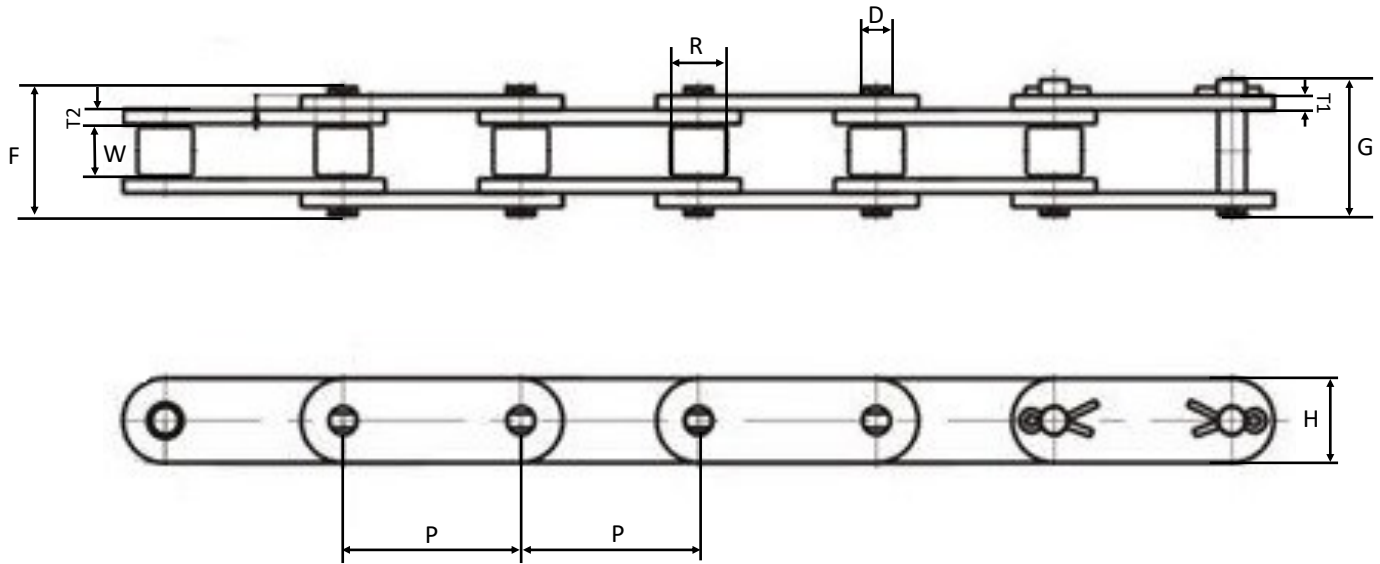

Les valeurs des dimensions se trouvent à la page suivante.

The value for the dimensions will be found on the following page.

SELECTION

Chaînes à rouleaux de type C – Double pas ANSI standard et type H Type C Roller Chain - Double Pitch ANSI standard and H type

# Chaîne Chain number	Pas Pitch		Largeur chaîne (min) Chain width	Largeur rouleau (max) Roller Width	Plaque Plate			Goupille Pin			Force de traction minimum ultime Ultimate minimum tensile strength KN / (lbs)	Poids approximatif Approximate Weight kg/m / (lb/ft)	Charge de service Working Load Kgs (lbs)
	P po/in	P mm			H mm (po/in)	T1 mm (po/in)	T2 mm (po/in)	D mm (po/in)	F mm (po/in)	G mm (po/in)			
	W mm (po/in)	R mm (po/in)			Épaisseur 1 Thickness 1	Épaisseur 2 Thickness 2	Diamètre max Max Diameter	Longueur max Max Length					
C2040*	1"	25.40	7.85 (0.30)	7.95 (0.31)	12.07 (0.47)	1.5 (0.05)	1.5 (0.05)	3.98 (0.156)	17.8 (0.70)	18.8 (0.74)	14.1 (3172)	0.50 (0.336)	269.88 (595)
C2040H**	1"	25.40	7.85 (0.30)	7.95 (0.31)	12.07 (0.47)	2.0 (0.07)	2.0 (0.07)	3.96 (0.155)	18.8 (0.74)	19.9 (0.78)	14.1 (3172)	0.65 (0.437)	N/A
C2042**	1"	25.40	7.85 (0.30)	15.88 (0.62)	12.07 (0.47)	1.5 (0.05)	1.5 (0.05)	3.98 (0.156)	17.8 (0.70)	18.8 (0.74)	14.1 (3172)	0.84 (0.565)	269.88 (595)
C2050*	1-1/4"	31.75	9.40 (0.37)	10.16 (0.39)	15.09 (0.59)	2.0 (0.07)	2.0 (0.07)	5.09 (0.20)	21.8 (0.85)	22.6 (0.88)	22.2 (4994)	0.78 (0.524)	439.98 (970)
C2052**	1-1/4"	31.75	9.40 (0.37)	19.05 (0.74)	15.09 (0.59)	2.0 (0.07)	2.0 (0.07)	5.09 (0.20)	21.8 (0.85)	22.6 (0.88)	22.2 (4994)	1.27 (0.8534)	439.98 (970)
C2060*	1-1/2"	38.10	12.57 (0.49)	11.91 (0.46)	18.10 (0.71)	2.42 (0.09)	2.42 (0.09)	5.94 (0.23)	25.9 (1.01)	27.7 (1.09)	31.8 (7154)	1.12 (0.753)	N/A
C2060H*	1-1/2"	38.10	12.57 (0.49)	10.91 (0.42)	18.10 (0.71)	3.25 (0.127)	3.25 (0.127)	5.94 (0.23)	29.2 (1.14)	31.6 (1.24)	31.8 (7154)	1.44 (0.968)	639.56 (1410)
C2062*	1-1/2"	38.10	12.57 (0.49)	22.23 (0.87)	18.10 (0.71)	2.42 (0.09)	2.42 (0.09)	5.94 (0.23)	25.9 (1.01)	27.7 (1.09)	31.8 (7154)	1.61 (1.082)	N/A
C2062H**	1-1/2"	38.10	12.57 (0.49)	22.23 (0.87)	18.10 (0.71)	3.25 (0.127)	3.25 (0.127)	5.94 (0.23)	29.2 (1.14)	31.6 (1.24)	31.8 (7154)	2.07 (1.391)	639.56 (1410)
C2080*	2"	50.80	15.75 (0.62)	15.88 (0.625)	24.13 (0.94)	3.25 (0.127)	3.25 (0.127)	7.94 (0.312)	33.5 (1.31)	35.0 (1.37)	56.7 (12755)	2.08 (1.398)	N/A
C2080H*	2"	50.80	15.75 (0.62)	15.88 (0.625)	24.13 (0.94)	4.0 (0.157)	4.0 (0.157)	7.92 (0.311)	36.2 (1.42)	39.4 (1.55)	56.7 (12755)	2.54 (1.707)	1632.93 (3600)
C2082*	2"	50.80	15.75 (0.62)	28.58 (1.12)	24.13 (0.94)	3.25 (0.127)	3.25 (0.127)	7.94 (0.312)	33.5 (1.31)	35.0 (1.37)	56.7 (12755)	3.12 (2.097)	1088.62 (2400)
C2082H*	2"	50.80	15.75 (0.62)	28.58 (1.12)	24.13 (0.94)	4.0 (0.157)	4.0 (0.157)	7.92 (0.311)	36.2 (1.42)	39.4 (1.55)	56.7 (12755)	3.58 (2.406)	1088.62 (2400)
C2100*	2-1/2"	63.50	18.90 (0.74)	19.05 (0.74)	30.17 (1.18)	4.0 (0.157)	4.0 (0.157)	9.54 (0.375)	41.1 (1.61)	44.7 (1.759)	88.5 (19909)	3.01 (2.023)	N/A
C2100H*	2-1/2"	63.50	18.90 (0.74)	19.05 (0.74)	30.17 (1.18)	4.8 (0.18)	4.8 (0.18)	9.54 (0.375)	44.5 (1.751)	50.6 (1.992)	88.5 (19909)	3.50 (2.352)	1741.79 (3840)
C2010H**	2-1/2"	63.50	18.90 (0.74)	19.05 (0.74)	30.17 (1.18)	4.80 (0.18)	4.8 (0.18)	9.53 (0.375)	43.6 (1.72)	46.9 (1.85)	88.5 (19909)	3.56 (2.392)	N/A
C2012**	2-1/2"	63.50	18.90 (0.74)	39.67 (1.561)	30.17 (1.18)	4.0 (0.157)	4.0 (0.157)	9.54 (0.375)	41.1 (1.61)	44.7 (1.759)	88.5 (19909)	4.83 (3.246)	N/A
C2012H**	2-1/2"	63.50	18.90 (0.74)	39.67 (1.561)	30.17 (1.18)	4.80 (0.18)	4.80 (0.18)	9.53 (0.375)	43.6 (1.716)	46.9 (1.84)	88.5 (19909)	5.38 (3.615)	N/A
C2120*	3"	76.20	25.22 (0.99)	22.23 (0.87)	36.2 (1.42)	4.80 (0.18)	4.80 (0.18)	11.11 (0.437)	50.8 (1.99)	54.3 (2.13)	127.0 (28570)	4.66 (3.131)	N/A
C2120H**	3"	76.20	25.22 (0.99)	22.23 (0.87)	36.2 (1.42)	5.60 (0.22)	5.60 (0.22)	11.10 (0.437)	53.5 (2.10)	57.5 (2.26)	127.0 (28570)	5.26 (3.535)	2440.32 (5380)
C2122**	3"	76.20	25.22 (0.99)	44.42 (1.748)	36.2 (1.42)	4.80 (0.18)	4.80 (0.18)	11.11 (0.437)	50.8 (1.99)	54.3 (2.13)	127.0 (28570)	7.66 (5.147)	N/A
C2122H**	3"	76.20	25.22 (0.99)	44.45 (1.749)	36.2 (1.42)	5.60 (0.22)	5.60 (0.22)	11.10 (0.437)	53.5 (2.10)	57.5 (2.26)	127.0 (28570)	8.26 (5.551)	2440.32 (5380)
C2160*	4"	101.60	31.75 (1.24)	28.58 (1.125)	48.26 (1.89)	6.40 (0.25)	6.40 (0.25)	14.29 (0.562)	65.5 (2.57)	69.6 (2.74)	226.8 (51021)	8.15 (5.477)	N/A
C2160H*	4"	101.60	31.75 (1.24)	28.58 (1.125)	48.26 (1.89)	7.20 (0.28)	7.20 (0.28)	14.27 (0.562)	68.2 (2.68)	73.0 (2.87)	226.8 (51021)	9.06 (6.088)	4168.51 (9190)
C2162**	4"	101.60	31.75 (1.24)	57.15 (2.24)	48.26 (1.89)	6.40 (0.25)	6.40 (0.25)	14.29 (0.562)	65.5 (2.57)	69.6 (2.74)	226.8 (51021)	13.00 (8.736)	N/A
C2162H**	4"	101.60	31.75 (1.24)	57.15 (2.24)	48.26 (1.89)	7.20 (0.28)	7.20 (0.28)	14.27 (0.562)	68.2 (2.68)	73.0 (2.87)	226.8 (51021)	13.84 (9.300)	4168.51 (9190)

*: Ce type de chaîne est disponible sur demande seulement // This type of chain is available on demand only

** : À développer avec le fournisseur // To develop with the supplier

SELECTION

Chaînes à rouleaux de type o-ring / O-ring type Roller Chain

# Chaîne Chain number	Pas Pitch		Largeur chaîne (min) Chain width	Largeur rouleau (max) Roller Width	Plaque Plate			Goupille Pin			Force de traction minimum ultime Ultimate minimum tensile Strength KN / (lbs)	Poids approximatif Approximative Weight kg/m / (lb/ft)	Charge de service Working Load kgs (lbs)
	P po/in	P mm			H mm (po/in)	T1 mm (po/in)	T2 mm (po/in)	D mm (po/in)	F mm (po/in)	G mm (po/in)			
	W mm (po/in)	R mm (po/in)			H mm (po/in)	T1 mm (po/in)	T2 mm (po/in)	D mm (po/in)	F mm (po/in)	G mm (po/in)			
40 (O-RING CHAIN)*	1/2"	12.700	7.85 (0.30)	7.95 (0.31)	12.00 (0.47)	1.50 (0.05)	1.50 (0.05)	3.96 (0.15)	18.3 (0.72)	19.6 (0.77)	14.1 (3172)	0.67 (0.450)	N/A
50 (O-RING CHAIN)*	5/8"	15.875	9.40 (0.37)	10.16 (0.39)	15.09 (0.59)	2.00 (0.078)	2.00 (0.078)	5.08 (0.19)	23.1 (0.90)	24.8 (0.97)	22.2 (4994)	1.19 (0.799)	N/A
60 (O-RING CHAIN)*	3/4"	19.050	12.57 (0.49)	11.91 (0.46)	18.00 (0.70)	2.42 (0.09)	2.42 (0.09)	5.94 (0.23)	28.5 (1.12)	30.4 (1.19)	31.8 (7154)	1.62 (1.089)	N/A
80 (O-RING CHAIN)*	1"	25.400	15.75 (0.62)	15.88 (0.62)	24.00 (0.94)	3.25 (0.12)	3.25 (0.12)	7.95 (0.31)	35.6 (1.40)	37.3 (1.46)	56.7 (12755)	2.70 (1.814)	N/A
100 (O-RING CHAIN)*	1-1/4"	31.750	18.95 (0.74)	19.05 (0.74)	30.00 (1.18)	4.00 (0.15)	4.00 (0.15)	9.53 (0.37)	43.3 (1.70)	47.0 (1.85)	88.5 (19909)	3.94 (2.648)	N/A
120 (O-RING CHAIN)*	1-1/2"	38.100	25.22 (0.99)	22.23 (0.87)	35.70 (1.40)	4.80 (0.18)	4.80 (0.18)	11.11 (0.43)	54.0 (2.12)	57.5 (2.26)	127.0 (28570)	6.34 (4.260)	N/A

*: Ce type de chaîne est disponible sur demande seulement // This type of chain is available on demand only

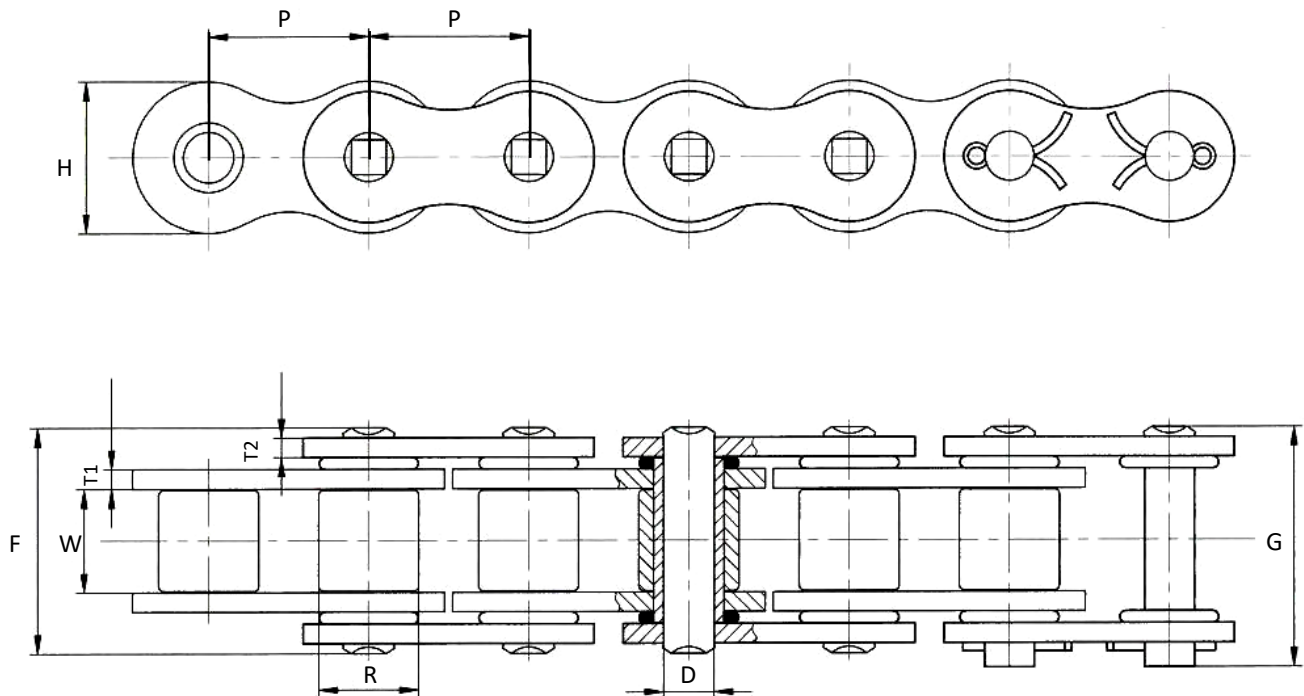

SELECTION

Chaînes à rouleaux de type HD – ANSI standard Type HD Roller Chain - ANSI standard

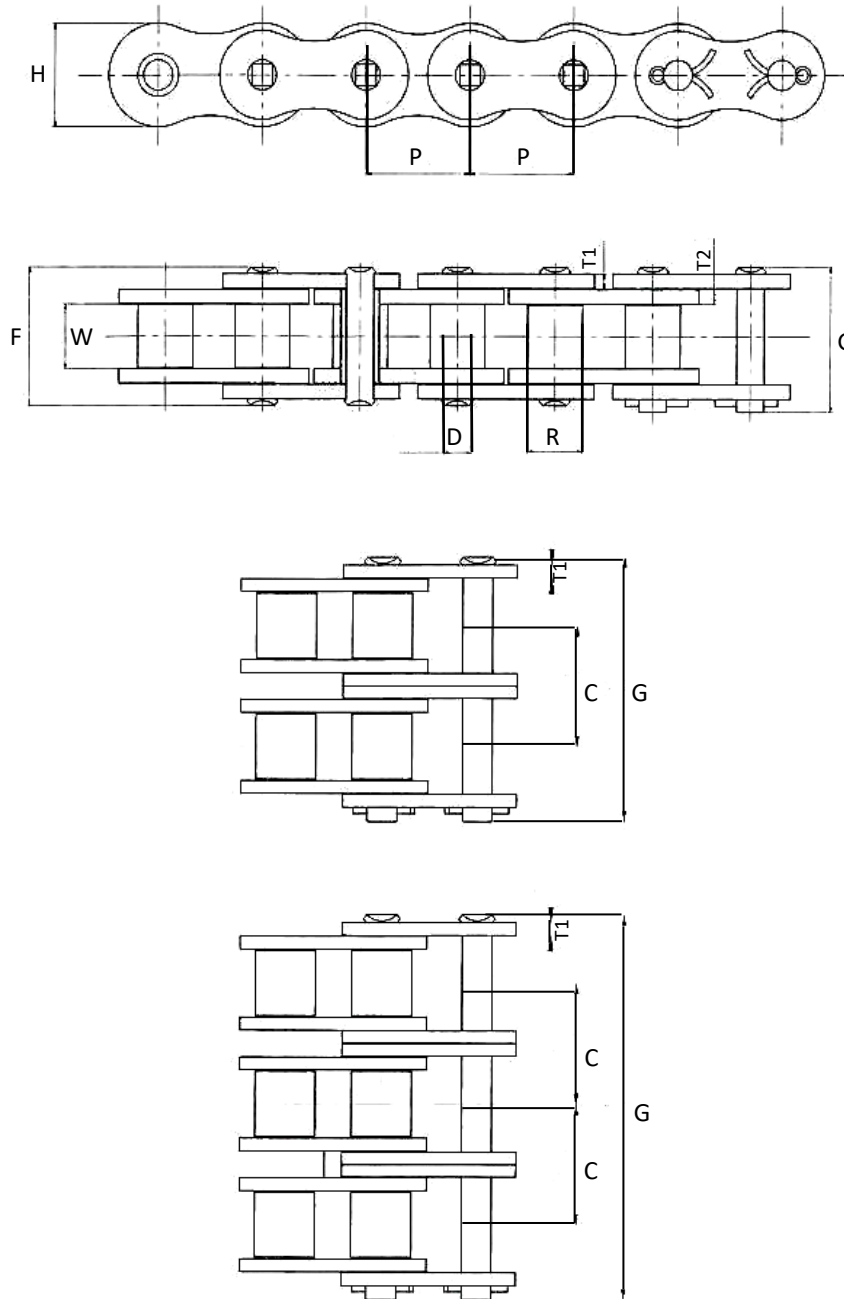

Les valeurs des dimensions se trouvent à la page suivante.

The value for the dimensions will be found on the following page.

SELECTION

Chaînes à rouleaux de type HD – ANSI standard Type HD Roller Chain - ANSI standard

# Chaîne Chain number	Pas Pitch		Largeur chaîne (min) Chain width	Largeur rouleau (max) Roller Width	Plaque Plate			Goupille Pin			Pas apparent Transverse Pitch	Force de traction minimum ultime Ultimate minimum tensile strength kN / (lbs)	Poids approximatif Approximative Weight kg/m / (lb/ft)	Charge de service Working Load kgs (lbs)
					Hauteur max Max Height	Épaisseur 1 Thickness 1	Épaisseur 2 Thickness 2	Diamètre max Max Diameter	Longueur max Max Length	C				
	P po/in	P mm	W mm (po/in)	R mm (po/in)	H mm (po/in)	T1 mm (po/in)	T2 mm (po/in)	D mm (po/in)	F mm (po/in)	G mm (po/in)	C mm (po/in)			
60HD-1	3/4"	19.05	12.57 (0.49)	11.91 (0.46)	18.00 (0.70)	3.25 (0.127)	3.25 (0.127)	5.94 (0.23)	29.2 (1.14)	31.0 (1.22)	—	48.1 (10821)	1.87 (1.257)	N/A
60HD-2*	3/4"	19.05	12.57 (0.49)	11.91 (0.46)	18.00 (0.70)	3.25 (0.127)	3.25 (0.127)	5.94 (0.23)	55.3 (2.17)	57.1 (2.24)	26.11 (1.02)	96.1 (21619)	3.71 (2.493)	N/A
60HD-3*	3/4"	19.05	12.57 (0.49)	11.91 (0.46)	18.00 (0.70)	3.25 (0.127)	3.25 (0.127)	5.94 (0.23)	81.4 (3.20)	83.2 (3.27)	26.11 (1.02)	144.0 (32394)	5.54 (3.723)	N/A
80HD-1	1"	25.40	15.75 (0.62)	15.88 (0.62)	24.00 (0.94)	4.00 (0.157)	4.00 (0.157)	7.92 (0.31)	36.2 (1.42)	37.7 (1.48)	—	81.5 (18334)	3.11 (2.090)	N/A
80HD-2*	1"	25.40	15.75 (0.62)	15.88 (0.62)	24.00 (0.94)	4.00 (0.157)	4.00 (0.157)	7.92 (0.31)	68.8 (2.70)	70.3 (2.76)	32.59 (1.28)	163.0 (36669)	6.18 (4.153)	N/A
80HD-3*	1"	25.40	15.75 (0.62)	15.88 (0.62)	24.00 (0.94)	4.00 (0.157)	4.00 (0.157)	7.92 (0.31)	101.4 (3.98)	102.9 (4.05)	32.59 (1.28)	244.0 (54890)	9.42 (6.330)	N/A
100HD-1	1-1/4"	31.75	18.90 (0.74)	19.05 (0.75)	30.00 (1.18)	4.80 (0.188)	4.80 (0.188)	9.53 (0.37)	43.6 (1.71)	46.9 (1.84)	—	124.0 (27895)	4.53 (3.044)	N/A
100HD-2*	1-1/4"	31.75	18.90 (0.74)	19.05 (0.75)	30.00 (1.18)	4.80 (0.188)	4.80 (0.188)	9.53 (0.37)	82.7 (3.25)	86.0 (3.38)	39.09 (1.53)	247.0 (55565)	9.03 (6.068)	N/A
100HD-3*	1-1/4"	31.75	18.90 (0.74)	19.05 (0.75)	30.00 (1.18)	4.80 (0.188)	4.80 (0.188)	9.53 (0.37)	121.8 (4.79)	125.1 (4.92)	39.09 (1.53)	371.0 (83461)	13.02 (8.749)	N/A
120HD-1	1-1/2"	38.10	25.22 (0.99)	22.23 (0.87)	35.70 (1.40)	5.60 (0.22)	5.60 (0.22)	11.10 (0.43)	53.5 (2.10)	57.5 (2.26)	—	167.0 (37568)	6.60 (4.435)	N/A
120HD-2*	1-1/2"	38.10	25.22 (0.99)	22.23 (0.87)	35.70 (1.40)	5.60 (0.22)	5.60 (0.22)	11.10 (0.43)	102.4 (4.03)	106.4 (4.18)	48.87 (1.92)	333.0 (74912)	13.13 (8.823)	N/A
120HD-3*	1-1/2"	38.10	25.22 (0.99)	22.23 (0.87)	35.70 (1.40)	5.60 (0.22)	5.60 (0.22)	11.10 (0.43)	151.2 (5.95)	155.2 (6.11)	48.87 (1.92)	500.0 (112481)	19.64 (13.198)	N/A
140HD-1	1-3/4"	44.45	25.22 (0.99)	25.40 (0.99)	41.00 (1.61)	6.40 (0.25)	6.40 (0.25)	12.70 (0.5)	57.6 (2.26)	62.2 (2.44)	—	218.0 (49041)	8.30 (5.577)	N/A
140HD-2*	1-3/4"	44.45	25.22 (0.99)	25.40 (0.99)	41.00 (1.61)	6.40 (0.25)	6.40 (0.25)	12.70 (0.5)	109.8 (4.32)	114.1 (4.49)	52.20 (2.05)	435.0 (97858)	16.60 (11.155)	N/A
140HD-3*	1-3/4"	44.45	25.55 (1.00)	25.40 (0.99)	41.00 (1.61)	6.40 (0.25)	6.40 (0.25)	12.70 (0.5)	162.0 (6.37)	166.6 (6.55)	52.20 (2.05)	653.0 (146900)	24.90 (16.732)	N/A
160HD-1	2"	50.80	31.55 (1.24)	28.58 (1.12)	47.80 (1.88)	7.20 (0.28)	7.20 (0.28)	14.27 (0.56)	68.2 (2.68)	73.0 (2.87)	—	279.0 (32764)	10.50 (7.056)	N/A
160HD-2*	2"	50.80	31.55 (1.24)	28.58 (1.12)	47.80 (1.88)	7.20 (0.28)	7.20 (0.28)	14.27 (0.56)	130.1 (5.12)	134.9 (5.31)	61.90 (2.43)	555.0 (124853)	20.20 (13.574)	N/A
160HD-3*	2"	50.80	31.55 (1.24)	28.58 (1.12)	47.80 (1.88)	7.20 (0.28)	7.20 (0.28)	14.27 (0.56)	192.0 (7.55)	196.8 (7.74)	61.90 (2.43)	833.0 (187393)	30.20 (20.294)	N/A

*: Ce type de chaîne est disponible sur demande seulement // This type of chain is available on demand only

Vérification de la chaîne à rouleaux / Verification of the roller chain

En général, la durée de vie utile de la chaîne est terminée lorsqu'elle ne s'engage plus convenablement sur la roue dentée en raison de son élongation ou de parties endommagées. Lorsque ceci se produit, il faut remplacer la chaîne.

Si la chaîne a été sélectionnée convenablement pour les conditions de ses applications, une longue durée de vie utile sera obtenue. Pour empêcher les dommages ou l'usure prématurée, la chaîne et les roues dentées doivent être vérifiées afin de déceler:

1. Un bruit anormal
2. Une vibration de la chaîne
3. Une chaîne qui se soulève sur la roue dentée
4. Un enroulement excessif de la chaîne autour de la roue dentée
5. Des déformations ou un pliage difficile de la chaîne
6. L'état et la qualité de lubrification
7. Un contact entre la chaîne et le carter de protection
8. L'apparence de la chaîne. Vérifier s'il y a des saletés, des traces de corrosion, des dommages sur la surface extérieure du rouleau, des marques de contact, etc. Vérifier aussi le bord intérieur, les surfaces des maillons extérieures et les bords de la surface des rivets.
9. Des dommages sur les surfaces des dents de la roue dentée, les surfaces latérales des dents et les zones d'engagement.
10. Un allongement dû à une usure excessive de la chaîne
11. Le pliage de la chaîne et la rotation du rouleau

Points de vérification

Lubrification

Lorsque la chaîne fonctionne, vérifier que l'huile se déplace vers les maillons et que la chaîne ou le disque rotatif sont immergés dans le bain d'huile, si applicable. Lorsque la chaîne est arrêtée, vérifiez s'il y a de la saleté ou des particules abrasives découlant d'une lubrification inadéquate. Lorsque la chaîne est retirée, le rivet du maillon de jonction et le bord intérieur de la douille doivent être vérifiés. Des dommages ou une coloration rouge ou rouge-brun indiquent une lubrification inadéquate ou insuffisante.

Pour la lubrification de la chaîne, voir la norme ASME.B29.1-2011.

In general, life of a roller chain is said to be reached when parts are damaged or when wear elongation prevent the chain to engage properly in the gear.

When this happens, replace the chain.

If roller selection and operating conditions are suitable, a rather long life with no unexpected trouble, can be expected. However, to prevent damages or premature wear, the chain and sprocket must be inspected and the following points verified to detect:

- 1. A strange noise*
- 2. An excessive chain vibration*
- 3. A chain that run up the sprocket*
- 4. A chain jammed onto the sprocket*
- 5. Deformations or stiff areas on the chain*
- 6. Adequate lubricating system and quality of oil*
- 7. No contact between the chain and the case*
- 8. The appearance of the chain. Check for external cleanliness, corrosive and lubrication conditions; also, look for scratches or other damage to the plate side and edge surfaces, pin edges, and roller surface.*
- 9. Damages on the sprocket teeth surfaces and teeth side surfaces and the mating zones.*
- 10. The wear elongation of the chain*
- 11. The articulation of the chain and the rotation of rollers*

Points of verification

Lubrification

During operation, check if the chain or rotating disc is immersed in lubricating oil. Also, check if there is lubricant at the clearance between the outer plater and inner plate. When the chain is stationary, check for dirt or abrasive particles as a result of improper lubrication. When the chain is removed, the connecting link pin and the edge of the inside of the bushing should be checked. Any damages or a red or reddish-brown colour is an indication of an improper lubrication.

For the chain lubrication, see ASME.B29.1-2011 standard.

Points de vérification

Plaque de liaison

Si la chaîne est soumise à des charges répétées, la plaque de liaison peut développer des cassures liées à la fatigue des maillons extérieurs. Les cassures dues à la fatigue sont difficiles à prévoir avant qu'elles ne produisent une fissure. Les fissures apparaissent habituellement au bord de l'orifice ou sur le côté du maillon extérieur (Fig. 1 et 2). Vérifier souvent les maillons extérieurs afin d'y déceler des fissures et d'éviter des accidents.



Fig. 1 Emplacements où les fissures risquent de se développer/
Positions where cracks are likely to develop

Points of verification

Link plate

If repeated loads over the maximum allowable load are put on the chain, fatigue breakage may happen on the link plate. It is difficult to notice initial cracking from fatigue breakage before they generate a breakage.

Usually, a crack develops at the edge of a hole or at the side of the link plate (Fig. 1 and 2). The presence of cracks should be checked carefully to prevent accidents.

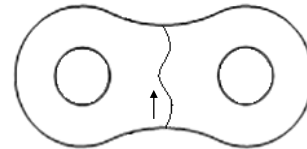

Fig. 2 Exemple d'une fissure/
Example of a crack

Rouleau

Des précautions doivent être prises pour éviter des charges dynamiques répétées sur des charges admissibles puisque des fissures liées à la fatigue peuvent se produire. Le rouleau doit être vérifié de la même manière que le maillon intérieur. Si des corps étrangers nuisent à l'engagement du rouleau et de la roue dentée, le rouleau peut être endommagé et une fissure peut apparaître (fig.3). Les chaînes endommagées par des bris dus à la fatigue doivent être remplacées.

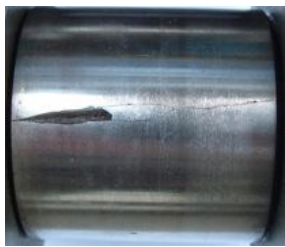

Fig. 3 - Une fissure produite sur le rouleau/
Crack on the roller

Roller

As with the link plate, if rollers are also subjected to loads exceeding the maximum allowable load, the repeated impact load between the chain and the sprockets may cause fatigue breakage. The roller should be checked in the same way as the link plate. If foreign bodies interfere with the engagement of the roller and sprocket, the roller may be damaged and a crack may develop. Chains damaged by fatigue breakage must be replaced.

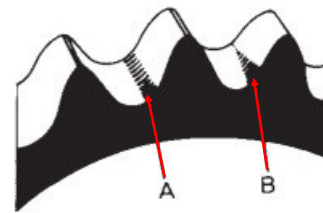

Fig. 4 Zones à vérifier pour déceler l'usure de la roue dentée/
Areas to check for wear on the sprocket

Roue dentée

L'engagement de la chaîne et de la roue dentée peut être vérifié en observant les surfaces du rouleau et des dents de la roue dentée. Un engagement approprié est obtenu lorsque la zone de contact est uniforme avec le point A (Fig. 4). Si la zone de contact présente des déséquilibres ou si le côté des dents use, la cause pourrait être une mauvaise installation de la roue dentée ou une torsion de la chaîne à rouleaux.

Une position d'engagement normal se situe légèrement au-dessus du bas de la dent. Si la tension reste du côté mou, le rouleau touchera légèrement le bas de la dent. Si une roue de renvoi ou un tendeur sont utilisés, la zone de contact se situera au centre du bas de la dent.

Sprocket

Chain and sprocket engagement can be checked by observing the roller and teeth surface. Proper engagement happens when the contact area is uniform with point A in Fig. 4. If the contact area is lopsided or the sides of the teeth are wearing away (B), this may have been caused by an improper installation of the sprocket or twisting of the roller chain.

The normal point of engagement is slightly up from the tooth bottom. If tension remains on the slack side, the roller will slightly touch the tooth bottom. When idlers or tensioners are used, the contact area will be the centre of the tooth bottom.

Points de vérification

Élongation de la chaîne

L'élongation est causée par l'usure de la goupille et de la douille et non par la déformation de la plaque de liaison. En mesurant l'élongation de la chaîne, il est possible d'évaluer la durée de vie utile restante de la chaîne.

Calcul de l'élongation de la chaîne

$$\text{Élongation de la chaîne}(\%) = \frac{\text{Longueur mesurée} - \text{Longueur théorique}}{\text{Longueur théorique}} \times 100$$

Où longueur mesurée (L) se mesure comme ci-dessous.



$$L = \frac{(L_1 + L_2)}{2}$$

À noter: Mesurer au moins 6 à 10 maillons pour limiter les erreurs. Un ruban à mesurer peut être utilisé s'il n'y a pas de pied à coulisse. Puisque les rubans à mesurer sont moins précis, la longueur mesurée doit être aussi longue que possible.

Et où $\text{Longueur théorique} = \text{Pas de la chaîne} \times \text{nombre de maillons}$

Points of verification

Chain Elongation

Chain elongation is caused not by deformation of the link plate, but by wear on the pin and bushing. Therefore, the remaining chain life can be estimated by measuring the chain elongation.

Calculation of the chain elongation

$$\text{Chain elongation}(\%) = \frac{\text{Measured length} - \text{Theoretical length}}{\text{Theoretical length}} \times 100'$$

When measured length (L) is measured as below

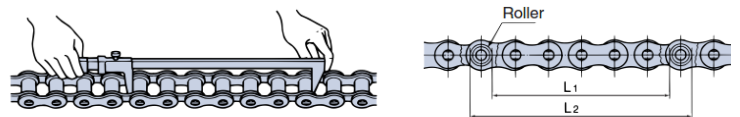

$$L = \frac{(L_1 + L_2)}{2}$$

N.B. When measuring, use at least 6 to 10 links to help keep any measuring error down to a minimum. A measuring tape may be used, if Vernier caliper is not available. However, measurements need to be taken over as many links as possible, to reduce measuring error.

And where $\text{Theoretical length} = \text{Chain pitch} \times \text{number of links}'$

Longueur standard et élongation 1.5% [mm (po)] ¹		Standard length and 1.5% elongation [mm (in)] ¹					
#maillon/link	Longueur/ length	25	35	41	40	50	60
6	Standard	38.10 (1.5)	57.15 (2.25)	76.20 (3.00)	76.20 (3.00)	95.25 (3.75)	114.30 (4.50)
	Élongation 1.5% 1.5% elongation	38.67 (1.52)	58.01 (2.28)	77.34 (3.05)	77.34 (3.05)	96.68 (3.81)	116.01 (4.57)
10	Standard	63.50 (2.50)	95.25 (3.75)	127.00 (5.00)	127.00 (5.00)	158.75 (6.25)	190.50 (7.50)
	Élongation 1.5% 1.5% elongation	64.45 (2.54)	96.68 (3.81)	128.91 (5.08)	128.91 (5.08)	161.13 (6.34)	193.36 (7.62)
#maillon/link	Longueur/ length	80	100	120	140	160	
6	Standard	152.40 (6.00)	190.50 (7.50)	228.60 (9.00)	266.70 (10.50)	304.80 (12.00)	
	Élongation 1.5% 1.5% elongation	154.69 (6.09)	193.36 (7.61)	232.03 (9.14)	270.70 (10.66)	309.37 (12.18)	
10	Standard	254.00 (10.00)	317.50 (12.5)	381.00 (15.00)	444.50 (17.50)	508.00 (20.00)	
	Élongation 1.5% 1.5% elongation	257.81 (10.15)	322.26 (12.69)	386.72 (15.23)	451.17 (17.76)	515.62 (20.30)	

N.B. Ce tableau s'applique aux roues dentées de 60 dents ou moins

N.B. This table only apply to sprockets with 60 teeth or less

Élongation maximale permise de la chaîne Maximum allowed elongation of the chain

Nombre de dents de la roue dentée / Quantity of teeth on the sprocket	Élongation (%) / Elongation (%)
60 ou moins / 60 or less	1.5
61—80	1.2
80-100	1.0
100 ou plus / 100 or more	0.8



CANIMEX GROUP IN BRIEF

50 Over **50 years** of partnership and innovation

7 **7 business units**

800 Over **800** qualified and dedicated **employees**

70 A world leader with a presence in more than **70 countries**

1,600,000 Production and warehousing facilities in Drummondville totalling more than **1,600,000 square feet**

1969 A tradition of excellence **since 1969**



Canimex head office

**MECHANICAL and
ELECTRICAL Division**

CANIMEX INC.

285, Saint-Georges,
Drummondville (Québec) Canada J2C 4H3
1 855 777-1335

canimex.com | mec@canimex.com